

SACTM

CRUISE CONTROL GRIP

INSTALLATION

Honda

Throttle Side:

- ① Carefully remove your current grip making sure to leave the plastic throttle sleeve in place.
- ② Trim the threads from the end of your throttle sleeve. (Fig. 1)

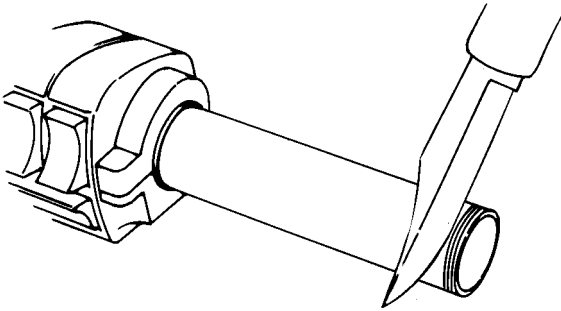

(Fig. 1)

- ③ Unscrew the knurled ring on the throttle side grip so two threads are showing. (Fig. 2)

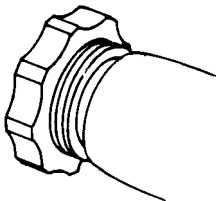

(Fig. 2)

- ④ Slide on the black rubber o-ring so that it is in contact with the throttle housing. Follow with the black teflon ring. (Fig. 3)

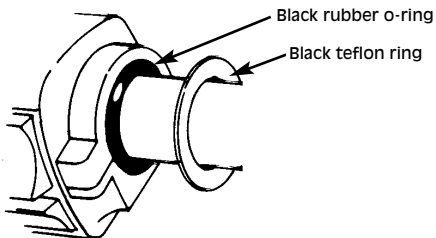

(Fig. 3)

- ⑤ Apply glue to the throttle sleeve. Most of the glue should be applied to the end of the sleeve away from the throttle housing.

- ⑥ Slide the grip onto throttle sleeve with one strong push (Fig. 4). **NOTE:** Be sure not to get any glue into the space between the throttle sleeve and the throttle sleeve housing, as well as the space between the throttle sleeve and the handle bar. Wipe up any excess glue immediately. Allow 6 hours for glue to set before using.

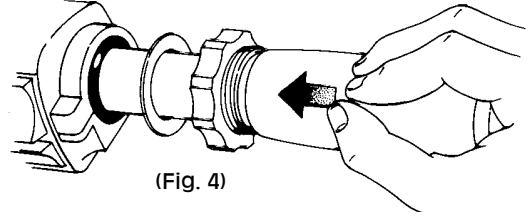

(Fig. 4)

Clutch Side:

- ① Remove clutch side grip by carefully cutting it away from the handlebar with a sharp knife.
- ② Apply glue to the bar. Most of the glue should be applied to the end of the bar away from the switch housing.
- ③ Slide the grip onto the bar with one strong push. Wipe away any excess glue immediately. Allow 6 hours for glue to set before using. (Fig. 5)

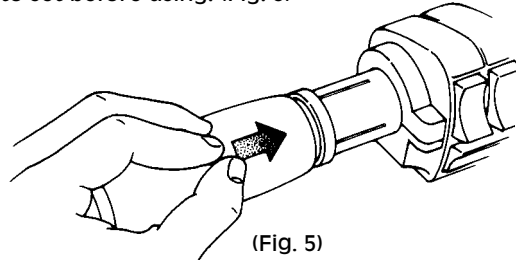

(Fig. 5)

Operation:

By adjusting the knurled ring you may increase or decrease drag on the throttle as you wish.

Engage

Disengage

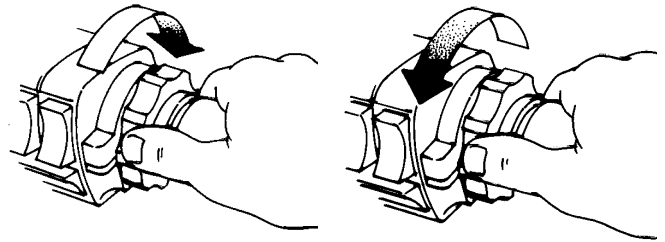

Maintenance:

Threads on the cruise control come pre-greased. Occasionally lubricate threads on cruise control to ensure optimum performance. White lithium grease or oil recommended for lubrication.

Note: Before applying glue make sure the surface is clean, dry and free of oil. Install grips immediately after glue has been applied.

Warning: Before operating motorcycle, make sure the throttle control snaps back to the idle position when released.

SACTM

2180 Elmwood Ave.
Buffalo, NY 14216
800-445-8946
www.coolsac.com